

Smart Wireless SOLUTIONS

SMARTSWITCH™ REMOTE CENTER PIVOT PUMP CONTROL

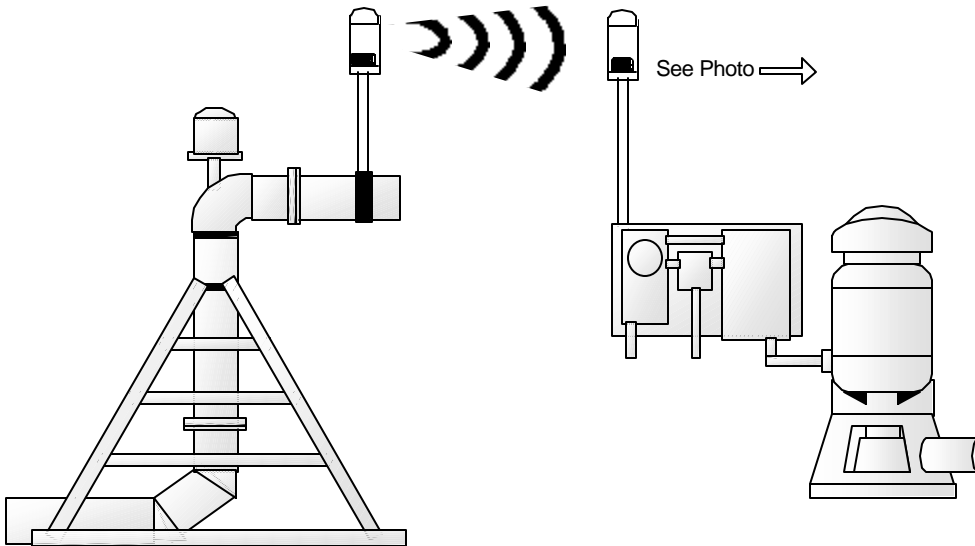

601R RECEIVER

MONITORS PIVOT OPERATION AND PROVIDES AUTOMATIC REMOTE CONTROL OF PUMP

PLUG AND PLAY SIMPLICITY

The Isaacs *SmartSwitch™* transmitter monitors the center pivot's wet circuit (for full remote control) or safety circuit. When the center pivot is turned on, the transmitter sends a "turn on" signal to the receiver at the pump. When the pivot is turned off or "safety's off," the transmitter sends the "turn off" signal.

No power is needed from the center pivot; the transmitter is battery powered with a long-life (up to 5 years) lithium battery. The transmitter also monitors its battery condition and notifies the receiver when a battery change is required.

At the pump site, the "turn on" signal from the transmitter causes the receiver relay(s) to energize the pump auto circuit. The "turn off" signal de-energizes the circuit to stop the pump.

ISAACS SPREAD SPECTRUM RELIABILITY

Isaacs *SmartSwitch™* systems utilize 900MHz, frequency hopping, spread spectrum digital radio technology to reliably transmit switch openings and closures from remote locations.

The Isaacs spread spectrum transmitter sends each actuation signal multiple times across a range of frequencies. With our proprietary communications protocol, data encoding, and unique digital addressing, Isaacs radios are virtually interference immune.

No FCC LICENSE REQUIRED

Optimum radio performance (up to 5 mile range) requires line of sight between transmitter and receiver with respect to ground or foliage. The Isaacs *SmartRepeater™* is available for sites with major obstacles or range beyond 5 miles.

No CONTROL WIRE NEEDED

Avoid the effort and expense of running control wire between pivot and pump. *SmartSwitch™* components are conveniently packaged in weatherproof enclosures with integrated internal antennas for quick and easy installation.

CONTACT US:



isaacs@IsaacsTech.com
www.IsaacsTech.com

Tel 509.529.2286
 Fax 509.529.2291

3380 Isaacs Avenue
 Walla Walla, WA 99362-8017
 USA

TYPICAL SYSTEM COMPONENTS

1 each	TS0603T	603T <i>SmartSwitch™</i> Transmitter
1 each	TS0601R	601R <i>SmartSwitch™</i> Receiver
1 each	TS0642A	SPDT Tx Interface Relay
1 each	TS0330	Low Voltage Disconnect
1 each	TS0380	Surge Suppressor, 120VAC