



Smart Wireless SOLUTIONS

SmartSwitch™ Remote Entry Alarm

Up to 5-mile LOS Range

No FCC License Required

Spread Spectrum Reliability

Virtually Interference Immune

Sends Alarm Signal if Switch Wires are Cut or Jumpered

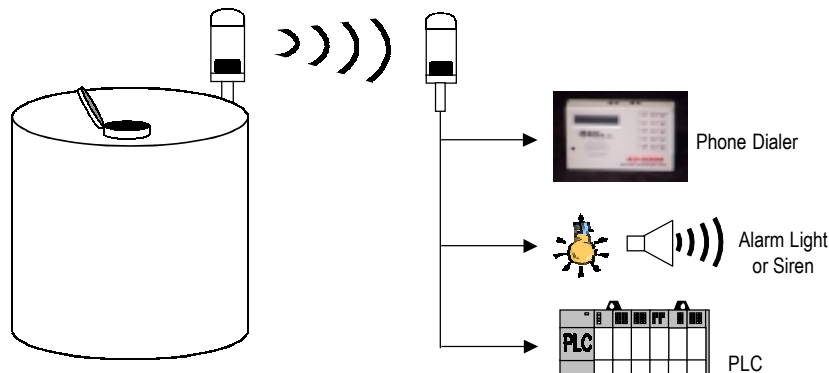

Protect Your Water Tank Against Unauthorized Access

Battery Powered Transmitter:

Still Sends Alarm During Power Outage

No Electrical Service Needed at Tank

Up to 5-Year Battery Life

Never Worry About Cable Breaks Again



Quick, Easy Installation

isaacs@IsaacsTech.com
www.IsaacsTech.com

Tel 800.237.2286
Tel 509.529.2286
Fax 509.529.2291

3380 Isaacs Avenue
Walla Walla, WA 99362
USA

The Isaacs SmartSwitch™ Transmitter monitors a hidden magnetic contact switch (normally closed) on the access opening. When the gap between the magnet and switch increases, the switch opens and the transmitter sends an alarm signal to the receiver at a secure remote site such as a control room. The transmitter also sends an alarm signal if the switch wires come loose or are cut or jumpered.

The transmitter is battery powered with a long-life (up to 5 years) lithium battery, so it still operates during power outages and can be used at tank sites without electrical service. The transmitter also monitors its battery voltage and notifies the receiver when a battery change is required.

At the control room, the receiver's relay outputs can turn on an alarm light or siren, activate a telephone/pager dialer, or provide an input to a PLC or other device.

Isaacs SmartSwitch™ systems utilize 900 MHz, frequency hopping, spread spectrum digital radio technology to reliably transmit switch openings and closures from remote locations.

The Isaacs spread spectrum transmitter sends each actuation signal multiple times across a range of frequencies. With our proprietary communications protocol, data encoding, and unique digital addressing, Isaacs radios are virtually interference immune.



Optimum radio performance (up to 5 mile range) requires line of sight between transmitter and receiver with respect to ground or foliage. The Isaacs SmartRepeater™ is available for sites with major obstacles or range beyond 5 miles.

Avoid the effort and expense of alarm wire installation between your remote tank and control room as well as wire's inherent vulnerabilities. SmartSwitch™ components are conveniently packaged in weatherproof enclosures with integrated internal antennas for quick and easy installation.

Typical System Components

1 each	TS0603T	SmartSwitch™ Transmitter
1 each	TS0601R	SmartSwitch™ Receiver
1 each	TS0355	Magnetic Contact Switch
1 each	TS0361	Voice/Pager Phone Dialer