



REMOTE SOIL MOISTURE MONITORING SYSTEM **Installation Instructions**

The Isaacs Moisture Monitoring System (IMMS) is designed to make tracking soil moisture levels easier and faster by reporting via radio to a central computer for data logging and graphic display. (NO FCC LICENSE IS REQUIRED to operate the radio.)

SUMMARY OF IMMS INSTALLATION STEPS

- Page 2) Review the site for a clear radio signal path between the Remote Moisture Tracker (RMT) and Receiver or Repeater.
- Page 3) Make sure you have the components needed for installation, and understand how they fit together.
- Page 4) Mount the receiver as high as possible in vicinity of building housing your computer. Run the 50' receiver cable through a mounting pipe and into your building.
- Page 4) Connect the receiver and power supply cables to the RJ45 junction box. Connect the computer to the RJ45 junction box. Plug in the receiver power supply.
- Page 5) Install IMMS software on your computer.
- Page 5) Program the Remote Moisture Tracker(s) (RMT) at the computer. Use the serial cable with 9 pin connectors at each end. Note: Tag each RMT with field, depth, and RMT sensor channels selected.

Note: When instructed in software to test communications to receiver, remove the serial cable used for programming the RMT, and replace it with the 9 pin to RJ45 cable. Plug the 9 pin connector into the computer COM port and the RJ45 connector into the RJ45 Junction box. Proceed to test RMT as instructed.
- Page 6) Install the RMT in the field. Be sure to locate the RMT in the designated field, and connect the sensor to the terminal screws designated for chosen sensor depth.
- Page 7) Install sensors in the soil
- Page 8) Connecting sensors to RMT(s), and frequently asked questions.
- Page 9) Warranty and Disclaimer

SITE REVIEW (to determine if you can receive clear wireless communications)

The transmitter in the RMT must be able to communicate with the receiver at the computer.

It is important to maintain line-of-sight communication between the RMT and the *SmartReceiver*[™] or *SmartRepeater*[™]. With good line-of-sight and adequate free space clearance, each transmitter has a range up to a mile. At marginal distances and/or poor line-of-sight and crop clearances, use of an **Isaacs Model 325 SmartRepeater**[™] can extend the range up to 5 miles. Multiple repeaters can be used if needed for more distance. A single repeater can serve all RMT(s) within range.

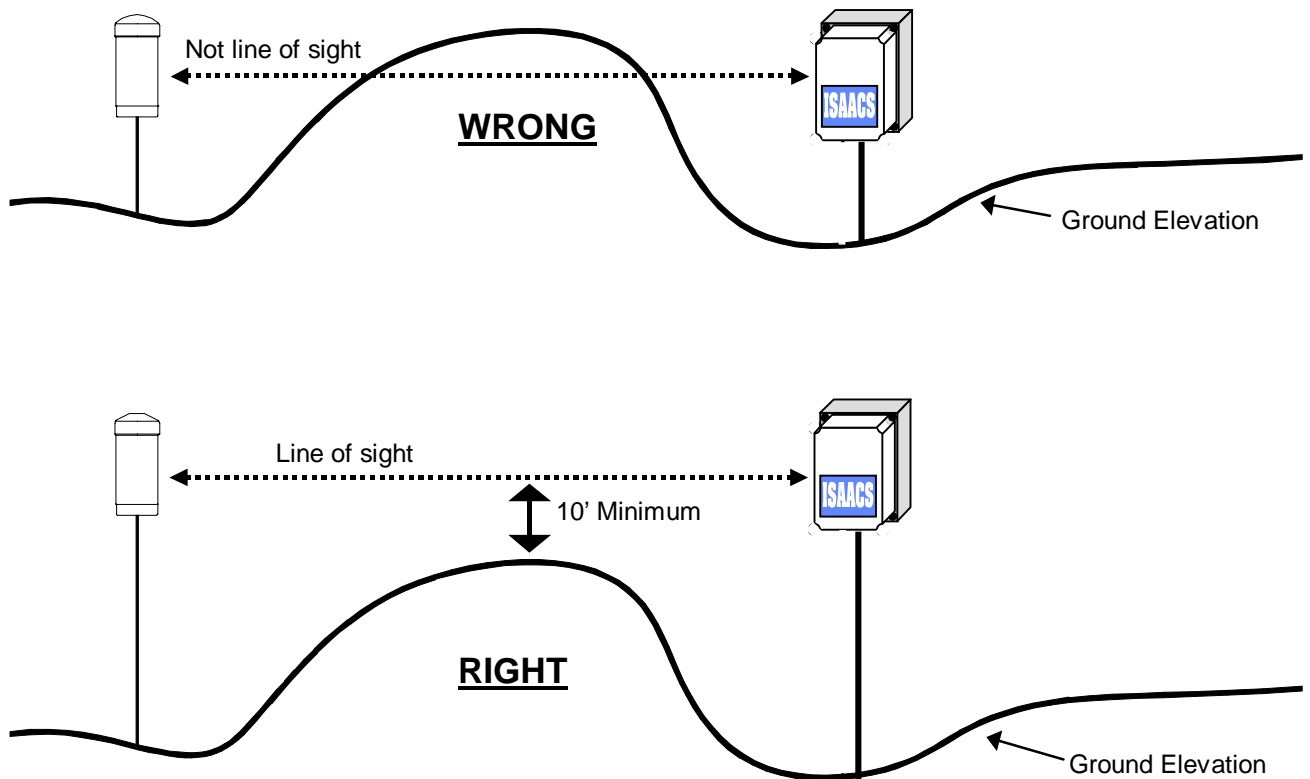

The site must have good clearance of all terrain and foliage.

The higher the Receiver and RMT are installed above the terrain and foliage, the better the results.

COMPONENTS NEEDED TO INSTALL THE REMOTE IMMS SYSTEM:

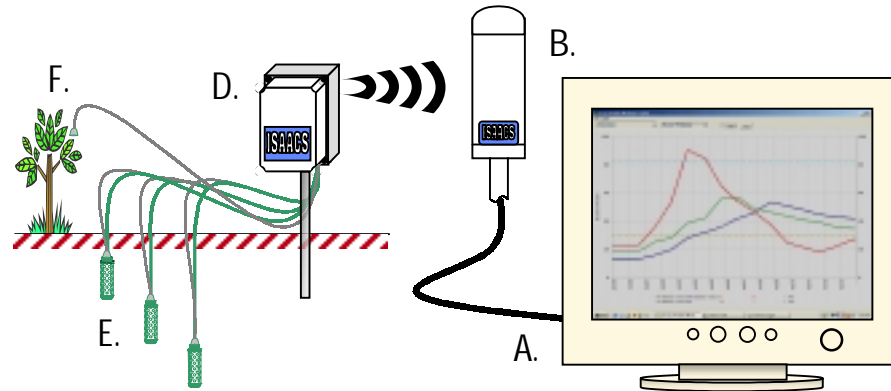

- A) **Isaacs Moisture Management Software (IMMS)** – *install in your computer*
- B) **SmartReceiver™** – *connects to the computer*
- Mounted as high as possible in vicinity of building housing your computer.
 - Receives wireless data from up to 256 Remote Moisture Trackers.
- C) **Base Installation Kit** - *includes...*
- RJ45 Wall Mount Junction Box.
 - Plug-in Power Supply connected by power cord to Junction Box.
 - RJ45 to 9 pin Serial Connector Cable.
 - 9 pin to 9 pin cable used to program the RMT.
- D) **Remote Moisture Tracker™ (RMT)** – *processes sensor data and sends it to computer*
- Accepts up to 6 soil moisture/temperature sensors and 2 additional temperature sensors.
 - Set to update readings every four hours. Other times can be set by changing jumper position on RMT circuit board. See page 6.
 - Battery powered.
- E) **Moisture / Temperature Sensor**– *installed in the ground, connected to RMT*
- A temperature sensor is imbedded in the moisture sensor. Green cables are from moisture sensor and Red Cables from temperature sensor. See page 6 for RMT terminal locations.
- F) **Temperature Sensors** – *connected to RMT*
- Additional sensors can be installed to read air, crop canopy, fruit core or other temperatures. The two Auxiliary Inputs are for this purpose. However, the RMT can read a combination of 8 temperature sensors by using the six soil moisture temperature slots. See page 6 for terminal locations.
- G) **Other Components** - *not furnished with system*
- Mast (pipe or conduit with 1” NPT fitting) to mount the receiver.
 - Perforated strut for post to mount the RMT
 - 18 ga. wire and waterproof connectors should the sensor wire need extending.

SmartReceiver™ INSTALLATION

The *TS0307R* receiver is sealed in an enclosure for outdoor use. It can be screwed onto a mast (usually a one inch pipe or tube with the power and data cable running through the pipe.)

- A) A single 50 ft. long cable with lines for power and data are attached to the receiver. This cable can be brought indoors through a 1/4" hole.
- B) The cable will be connected to a RJ45 Junction Box that can be attached to a wall near the computer.
- C) A RJ45 x DB-9 cable is furnished to connect between the Junction Box and the computer COM Port.
- D) A 12VDC plug in power supply is connected to the Junction Box.
- E) Also furnished is a separate short serial cable to program the RMT. (Connects between the RMT and the computer COM Port)

Place the receiver as high as possible. The RMT should communicate with the Receiver, or a properly situated Repeater, within one-half to one mile, line-of-sight.

CAUTION: The Power Supply must be unplugged (not connected to electricity) while wiring. If wires to the Power Supply are replaced, maintain DC polarity.

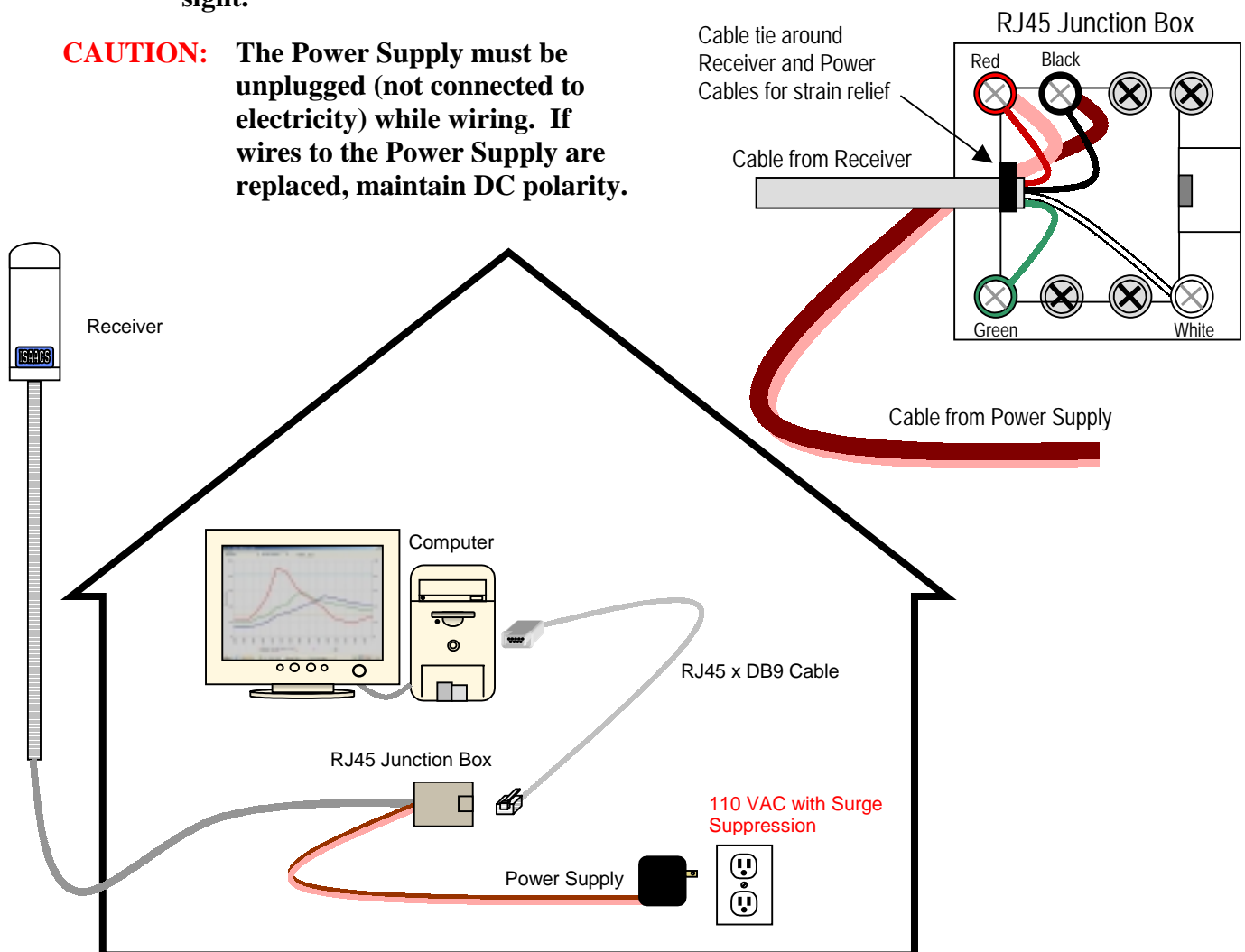

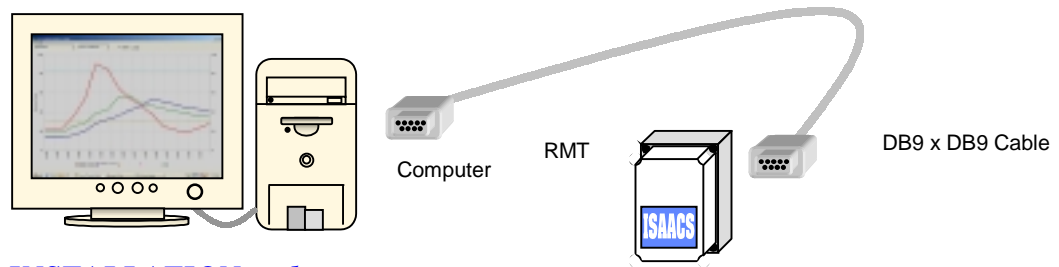

SOFTWARE INSTALLATION and PROGRAMMING THE REMOTE MOISTURE TRACKERS

At your computer you will need the following:

- A) Isaacs Moisture Management Software program on CD ROM Disc
- B) All the Remote Moisture Trackers
- C) The *SmartReceiver*[™] wired to the RJ45 Junction Box
- D) 9 pin cable for connection from the RMT to the computer COM Port (for programming)
- E) RJ45 to 9 pin Cable for connection between the computer and the Junction Box (When you finish programming the RMT(s), and you are asked to test RMT communication, use this cable between the Receiver (RJ45 Junction Box) and Computer COM Port)

Computer System Minimum Requirements: Windows 95 or later operating system; 32 MB RAM; 150 MHz processor; 50 MB available memory, and an open COM PORT. Note: Windows 2000 operating system requires Isaacs version 2000 Software.

Here's how to complete the installation

CLOSE ALL PROGRAMS; including Anti-virus and other programs running in background

- A) When you insert the IMMS disc into your CD drive your computer should automatically start the install program. If the installation program doesn't start, push Windows Start button, select Run (from the menu), type D:\Setup (where D is CD drive designation), and click Okay. Follow the instructions.
- B) Be sure to keep track of where each Remote Moisture Tracker is to be located. We suggest the name represent the location. Also keep track of the sensor location on the Remote Moisture Tracker, so the right depth will be wired in the right location on the "Remote Moisture Sensor" board. Write the locations on a tag or piece of masking tape attached to the RMT. This can be printed out for you after you get through programming all the Remote Moisture Trackers.

Installation Tips - New software installations must be compatible with existing computer hardware and software; here are some things to look for:

- A) Make sure you have an ***open*** COM PORT available with a 9-pin connection at the back of your computer (sometimes marked "IOIOI").
Note: Palm Top programs can use a COM PORT. If you do not have another port available you will have to disable the Palm Top program or add another COM PORT.

REMOTE MOISTURE TRACKER (RMT) FIELD INSTALLATION

- A) Before installing the Remote Moisture Tracker(s) in the field, program it with your computer as outlined on page 5. ***Install the selected RMT in the designated field, and connect the sensors to the proper RMT terminal locations for the selected sensor depths.*** ***If you get this wrong, you won't be able to interpret the reported data..***
- B) The Remote Moisture Tracker (RMT) should be mounted as high as possible (preferably at least 10') above the maximum height of any surrounding vegetation. The higher off the vegetation the RMT is mounted, the better chance you have for good radio communications. For ease of mounting, use a perforated strut or comparable type support (available from most electrical suppliers) Screws and fender washers to mount the RMT to the perforated strut are furnished. ***Do not penetrate the RMT housing, as moisture will get inside and corrode the electronic components.***

Caution: *Make sure the RMT box is watertight.
Mount RMT with the strain relief cable fittings on the bottom.*

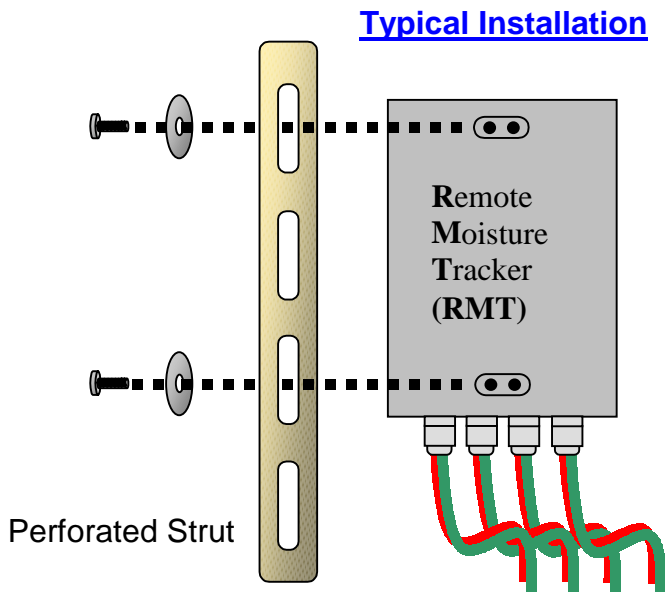

RMT printed circuit board layout

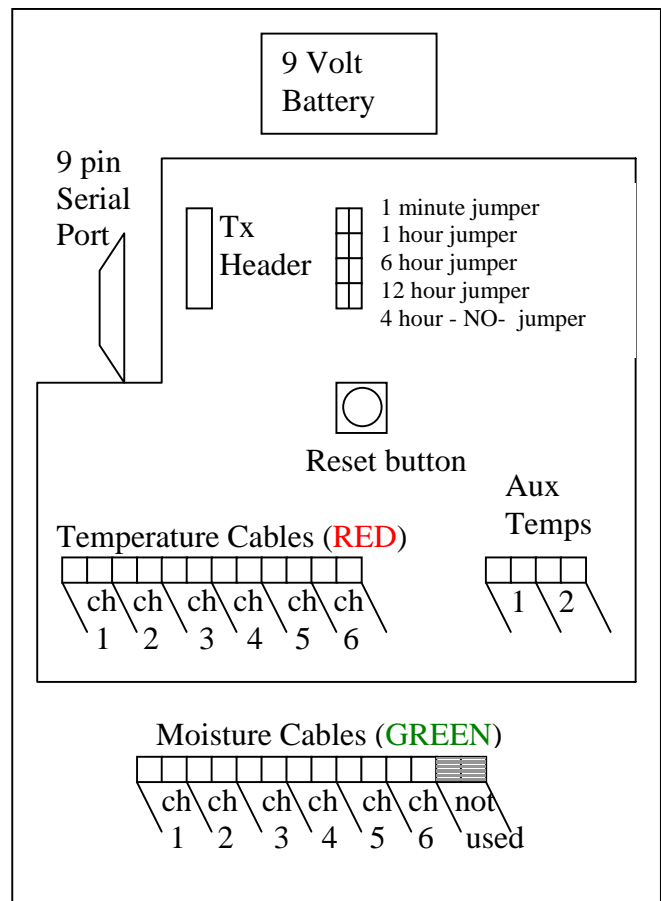

SENSOR INSTALLATION

The Quality of the information provided by the sensor is directly related to the quality of the installation. The Watermark sensor will perform best after planting and undergoing several irrigation cycles as the soil reestablishes itself. The basic procedure for planting a sensor is as follows:

Note: Soak the WATERMARK sensor overnight in water prior to installation.

- A) ***SENSOR PREPARATION:*** Soak the sensors overnight in irrigation water. Always “plant” a wet sensor. If time permits, wet the sensor for 30 minutes in the morning and let dry until evening, wet for 30 minutes, let dry overnight, wet again for 30 minutes the next morning and let dry again until evening. Soak over the next night and install WET. This will improve the sensor response in the first few irrigation cycles.
- B) ***SENSOR INSTALLATION:*** Make a sensor access hole to the desired depth using a 7/8” O.D. rod. Fill the hole with water and push the sensor down into the hole so it “bottoms out”. A length of 1/2” Class 315 PVC pipe will fit snugly over the sensor’s collar and can be used to push in the sensor. Thread the red and green wire leads through the length of pipe or through a notch cut in the end of the pipe so as to not damage the wire leads when pushing on the sensor. A good snug fit in the soil is important. If the length of pipe is to be left in the soil, this PVC can be solvent welded to the sensor collar with a PVC/ABS cement (IPS Weld-On #795 or equivalent).

If the PVC pipe is not left on the sensor, then backfill the hole so the sensor is buried. The sensor’s wires can easily be staked up for easy access. **If the PVC pipe is left on the sensor, then compact the soil around the surface to seal off the hole. Cap off or otherwise seal the top of the pipe so surface water will not infiltrate to the sensor and give a false reading.**

For very coarse or gravelly soils, an oversized hole (1” – 1-1/4”) may be needed to prevent abrasion damage to the sensor membrane. In this case, auger a hole to the desired depth and make a thick slurry with the soil and some water. Fill the hole with this slurry and then install the sensor. This will “grout in” the sensor to ensure a snug fit. **Note:** Sometimes “grouted” installations take longer to dry.

If sensors are removed, clean and dry them. They can be stored indefinitely in a clean, dry location.

Sensor Depth - Selecting sensor depth depends on the rooting depth of your crop as well as the soil profile

Locating Sensors – Use enough sensing stations to get a good overall view of the field. You might consider placing sensors at typical locations as well as other locations in the field such as a “hot spot” or “good production” area.

Important Notes:

- A) **It is important that the sensor has complete contact with the soil.**
- B) **Placing the sensor at the depth selected during RMT programming is vital to accurate interpretation of the reported data.**
- C) **Mark the free ends of the sensor wire with the site number and depth for the particular sensor.**

Wiring Sensors – Be sure to insert the marked wire leads into the RMT designated for that location. Wire each lead into the RMT connector channel you previously selected during set-up.

Note: The green leads go into the Soil Moisture Channels, and the red leads go in the Temperature channels.

If additional wire length is needed, simply splice the additional wire to the sensor's wire leads. **This wire splice must be fully waterproof** (3M Scotchpak, Duraseal heat shrink spliced connector, or equal). This wire can be extended up to 1000 feet with 18 gauge UF wire. Avoid long runs near power cables. The transient currents can affect the small current used by RMT. This can be checked by reading the sensors at both ends of the wire run.

Caution: Do not coil excess wire between the sensor and the RMT box as the coiled wire can cause irregular readings. These will show up on your graph. Cut the wire between the sensor and the RMT box to a proper fitted length.

TYPICAL QUESTIONS AND GENERAL INFORMATION

- A) Do I have to keep my computer on all the time?** Yes, your computer (in fact the system including repeaters, etc.) has to be on to receive and data log the soil moisture and temperature readings. If your computer is turned off, then it will miss the transmission of data for that time period.
- B) How long will I have a lost signal before the “Check Alarms” shows?**
The Alarm for a lost signal will not show on your screen until you have not had a signal from the RMT for 18 hrs.
- C) How do I know when to change RMT batteries?** There are two batteries in your Remote Moisture Tracker: a 9VDC battery to power the sensor circuit board and a 3VDC battery in the radio transmitter. The system is constantly monitoring the condition of both batteries. If either battery needs replacing, you will get a “Check Alarms” message on your computer screen.

To replace either battery you must remove the lid to the Remote Moisture Tracker.

Caution: the transmitter mounts on the inside of the enclosure cover and is connected to the sensor board by a cable. Do not pull the enclosure lid too far away from the enclosure body or damage to the components may result.

To change the transmitter battery, snap off its lid with the blade of a small screwdriver. Replace the battery and **push the reset button**. If you forget to push the reset button, that Remote Moisture Tracker may not operate.

- D) How do I know if a sensor wire is cut, or not hooked up?** If a **soil moisture sensor** is not hooked to the Remote Moisture Tracker board it will show a steady reading at the bottom of your graph. A very dry sensor will also read at the bottom of the graph. If a **temperature sensor** wire is not hooked up the temperature reading will be a constant 75 degrees.

Limited Warranty and Disclaimer: Isaacs & Associates, Inc. (Isaacs) warrants goods of its manufacture to be free of defective materials and faulty workmanship when used under normal and proper use and service. Commencing upon the date of shipment, the Isaacs warranty is valid for 12 months. To obtain warranty service, obtain an RGA number from Isaacs and send the product to Isaacs freight prepaid. Isaacs will repair or replace, at its discretion, those items deemed warrantable. This Limited Warranty does not apply in cases of improper installation or operation, misuse, alteration, abuse, accidental damage, tampering, repair by anyone other than Isaacs & Associates, Inc., or damage by, but not limited to, low voltage, voltage surges, or lightning. This Limited Warranty applies to Isaacs manufactured goods only. All other products, accessories or attachments used in conjunction with Isaacs manufactured goods, including batteries, will be covered solely by their own warranty, if any. Isaacs will not be liable for any direct, incidental, consequential, or accidental damage or loss whatsoever, caused by the malfunction of its manufactured goods due to products, accessories, or attachments of other manufacturers, including batteries, used in conjunction with Isaacs goods. Isaacs & Associates, Inc. will not be liable for any direct, incidental, consequential, or accidental damages resulting from use of Isaacs products or caused by any defects, failure or malfunction, whether a claim for damages is based on warranty, product design, system engineering, contract negligence or otherwise. It is the sole responsibility of the purchaser to consider and analyze the product and its design for fitness for a particular purpose. Isaacs & Associates, Inc. does hereby disclaim any liability for damages due to failure of the goods or system to perform as anticipated. Isaacs & Associates, Inc. does not authorize any person to act on its behalf to modify, vary or extend this warranty.

THE FORGOING IS THE BUYERS SOLE REMEDY AND IS EXCLUSIVE AND EXPRESSLY IN LIEU OF ALL OTHER WARRANTIES, OBLIGATIONS OR LIABILITIES, WHETHER WRITTEN, ORAL, EXPRESS, OR IMPLIED, INCLUDING WARRANTIES OF MERCHANTABILITY AND FITNESS FOR PARTICULAR PURPOSE.

Specifications and Technical Assistance: While Isaacs & Associates, Inc. may provide application assistance, verbally and through its literature, it is the customer's responsibility to determine suitability of the product to the application and correctness of the assistance. Specifications may change at any time and without notice. Although the information supplied is believed to be accurate and reliable, Isaacs & Associates, Inc. assumes no responsibility for its use.



3380 Isaacs Avenue Walla Walla, WA 99362
Phone: 509-529-2286 Fax: 509-529-2291
Toll Free: 800-237-2286 E-mail: isaacs@isaacstech.com
Web: www.isaacstech.com

Rev. 2-03
Soil Moisture